

# SHRINK-FIT HOLDER **SLIMLINE**



streuli technologies ag 8903 Birmensdorf  
[www.streuli-techno.ch](http://www.streuli-techno.ch)

**MST** corporation

Vol. 3  
1709 **ENG**



# Master Index

## SLIMLINE Product Overview

### Shrink-fit Heater

- Hot air heating type
- Induction heating type

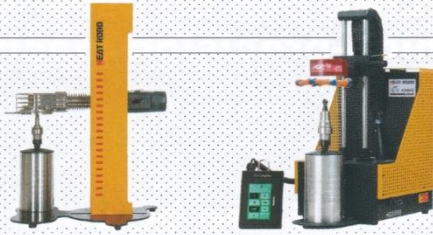

Specifications · Dimensions

### Overview · Model

BT30  
BT40  
BT50  
A40  
A50  
A63  
A100  
E25  
E32  
E40  
E50  
F63  
15T  
S20T  
RS20  
CT50

Product List

### MONO Series

- Slim, high accuracy and rigidity solid type

MONO 3°



MONO CURVE

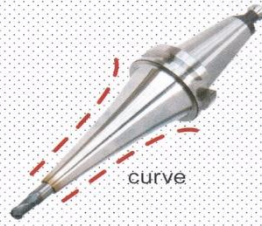

### Overview · Model

6type  
8type  
12type

Product List

### 2 PIECE TYPE

- Master holder and collet exchange modular type

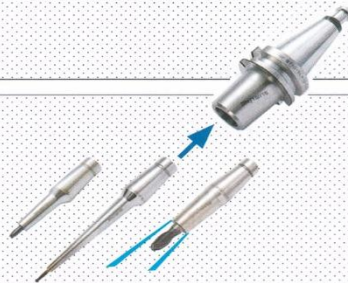

### Overview · Model

Product List

### BLACKUNO

- Ultraprecise run-out accuracy.



0.5 micron

### UNO



1 micron

### Overview · Model

Product List  
Short type  
Heavy-duty type

Product List

### HYPER version

- Gripping force and rigidity strengthening type

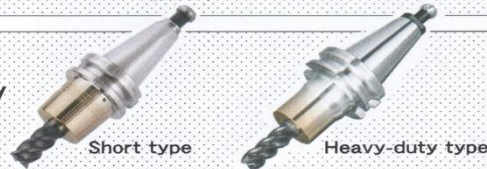

Short type

Heavy-duty type

### Overview · Model

Product List  
BT  
HSK  
DIN  
CAT.

Product List

### Z

- Anti-rotation and anti-pulling out capability



### Overview · Model

Product List

COLLET HOLDER  
Face Mill Arbor  
DETa-1 Collet Holder  
Retention Knob  
Coolant duct

### STRAIGHT arbor

- Straight shank type



### Overview · Model

TOOL SET UP STATION  
TOOL CAP TCC type  
TOOL SET UP STAND  
Goo CHECKER  
TEST BAR CHECKMATE  
TOOL HOLDER STORING CABINET  
ENDMILL HOUSE

### Related products

- Collet holder, Retention knob



### Peripheral equipment

- Washing machine, Work-table, Measuring equipment, Tool protection cover

Secure technical support  
Instructions for use  
Rigidity of SLIMLINE  
For high speed rotation  
Reference data  
Technical data  
Overseas sales network

### Technical Information



# MST's SHRINK-FIT HOLDER SLIMLINE is

a system to hold tools (carbide) firmly and accurately by heating and cooling the holder (steel).

It is different from the existing mechanism of chucking, and is a revolutionary holder that uses the science of material expansion and shrinkage. SLIMLINE is made of MST's exclusive material which is developed to shrink-fit (insert/remove tool) easily at low temperatures (300°C on average).

It also has a coefficient of thermal expansion that is 1.6 times higher than that of regular steel. Unlike conventional holders, SLIMLINE does not require any parts such as collets and nuts to hold tools. The simple mechanism can make the nose very thin, even to a thickness

of 1.5mm, and achieve the slimmest holder on the market. It creates less work-piece interference and minimizes cutter projection in order to achieve stable and high-rigidity machining.

Our line-up contains 4,000 kinds to offer the most suitable holder design for a large variety of work-piece shapes. These are benefits that only SLIMLINE can offer.

We promise that SLIMLINE will demonstrate its outstanding capabilities in 5-axis, micro-precision, heavy-duty, and many kinds of machining in order to improve accuracy, extend tool life and reduce production cost.

PAT.

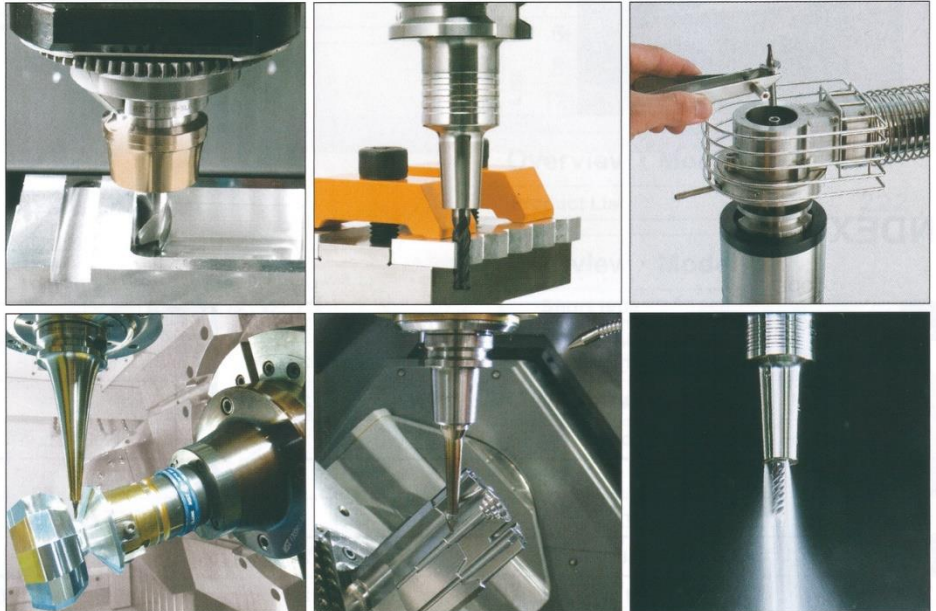
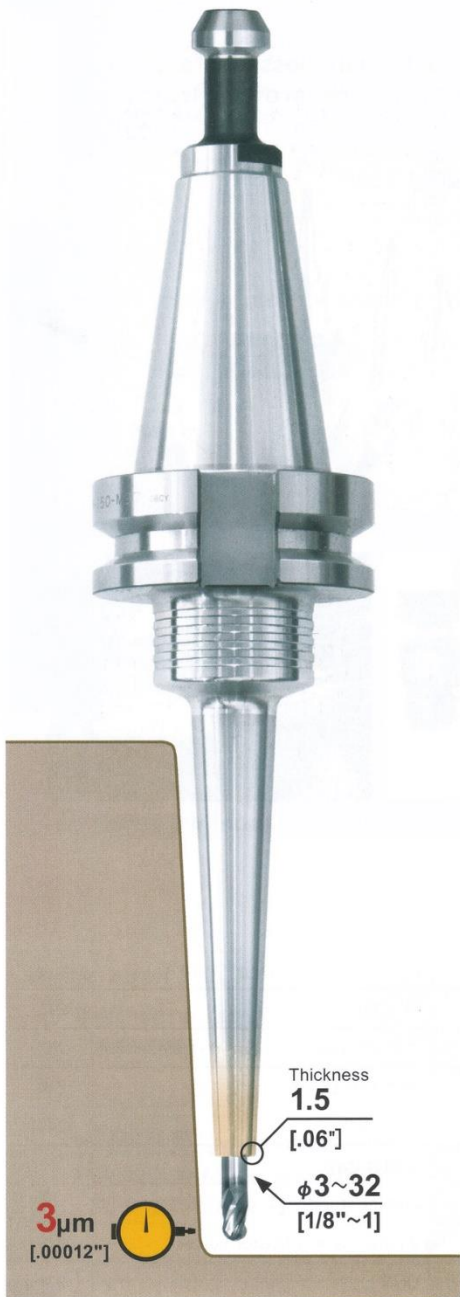

## Principle of shrinking technology

- A shrink-fit holder is a chucking system that utilizes the difference between the coefficients of thermal expansion of the holder material (steel) and the cutter (carbide).

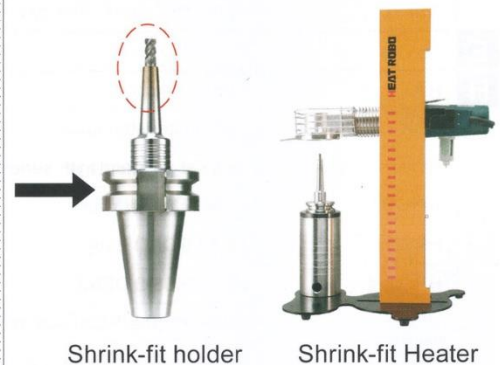
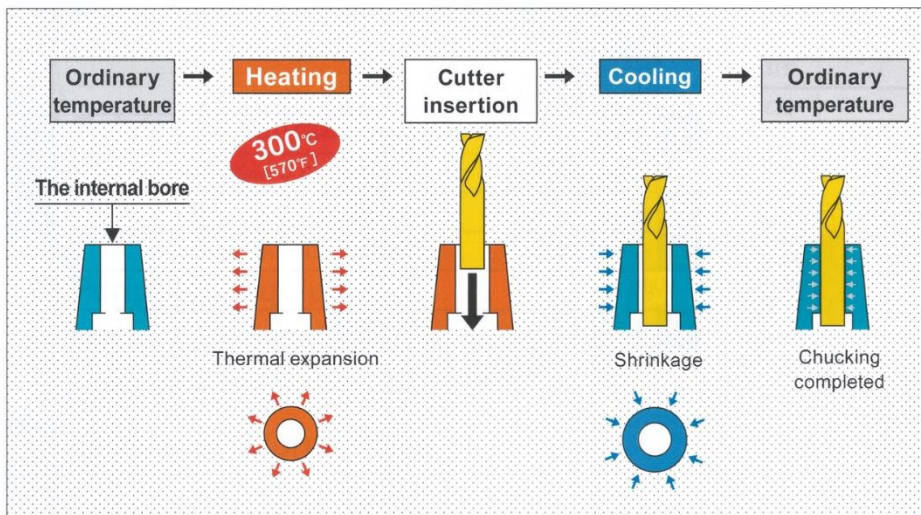



# Special material for shrink-fitting

Thermal expansion coefficient is 1.6 times higher.

- Special material is applied to MST's shrink-fit holders. This material has a higher coefficient of thermal expansion than that of competitor's shrink-fit holders, and you can shrink-fit at lower temperatures than that of competitors. Also, due to its superior heat resistance temperature, the holder doesn't receive any damage by overheating.

## Shrink-fitting temperature and heatproof temperature

### MST's SLIMLINE

#### Heatproof temperature

- You can heat it up to 720°C [1310°F] without any issue.

#### Shrink-fitting temperature

- Since the heating temperature is lower than 430°C [810°F], there is no adverse impact on holder life.

#### Coefficient of thermal expansion

- Between the holder(special material) and cutter(carbide).  
... $10.5 \times 10^{-6}$  mm/°C

1.6 times  
(Compared to competitors' holders)

The tip of the shrink-fit holder doesn't get burned due to the low heating temperature.

Long service life

Heatproof temperature  
**720°C**  
[1310°F]

Safety ratio

Maximum heating temperature  
**430°C**  
[810°F]

Shrink-fitting temperature

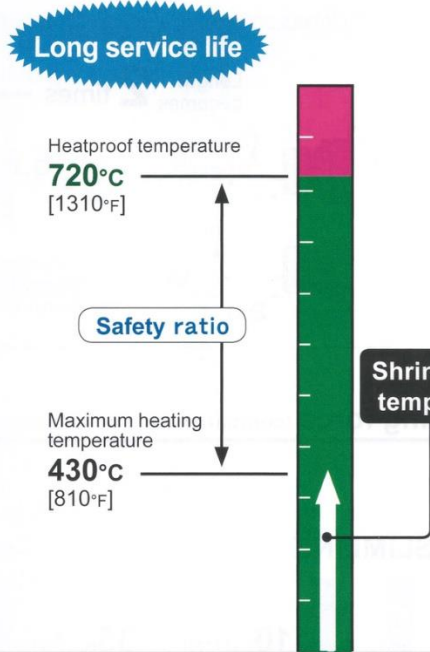

### Competitors' shrink-fit holder

#### Heatproof temperature

- Heat resistant temperature 580°C [1080°F], which is 20% lower than that of MST's proprietary material."

#### Shrink-fitting temperature

- They need 690°C [1270°F] for shrinking operation, and it means over heating. Thus, through repeated heating and cooling cycle, the internal bore of the shrink-fit holder deforms, and then the cutter doesn't go into the internal bore.

#### Coefficient of thermal expansion

- Between the holder(die steel) and cutter(carbide)... $6.5 \times 10^{-6}$  mm/°C

Short life

Maximum heating temperature  
**690°C**  
[1270°F]

Over Heating

Heatproof temperature  
**580°C**  
[1080°F]

- Oxidation
- Contraction of a bore dia.
- Reducing hardness

The shrink-fit holder burns due to the high heating temperature.

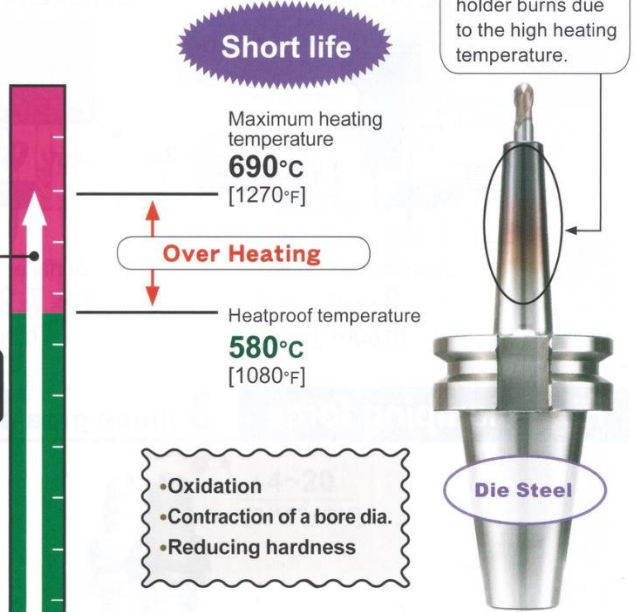

The difference between the maximum heating temperatures of MST's shrink-fit holders and our competitors' (3mm dia. shank cutter).

## The lifetime of shrink-fit holder

### MST's SLIMLINE

A shrink-fit temperature of a SLIMLINE holder is as low as 430°C maximum. It never exceeds a heatproof temperature of 720°C. Repetitious shrinkage fitting does not cause the deterioration of a holder.

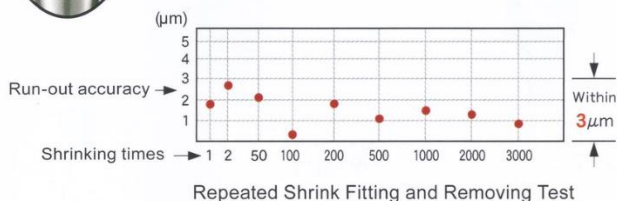

### Competitors' shrink-fit holder

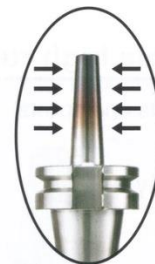

Heating several times at 700°C  
The internal bore  
Contraction of a bore dia.  
The cutter is difficult to insert.  
Run-out accuracy deteriorations.

Repeated over-heating causes change in properties of the materials, the holder will be reduced performance.



## Super-slim design

## Displaying the highest performance at deep machining

- The holder tip thickness with 1.5mm minimizes interference against the workpiece and jig fixtures.

### MST's SLIMLINE

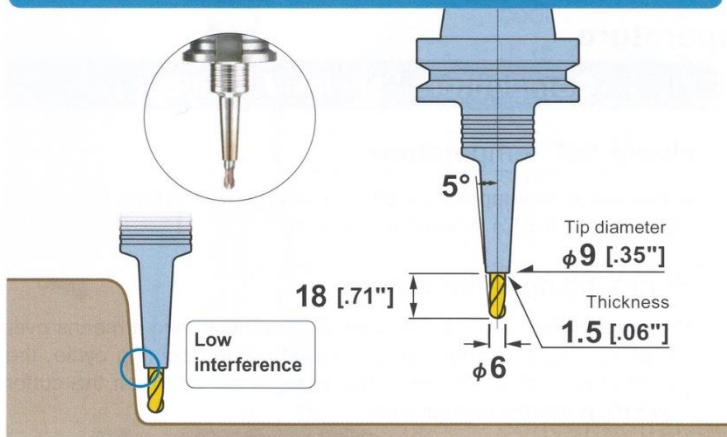

### Competitors' shrink-fit holder

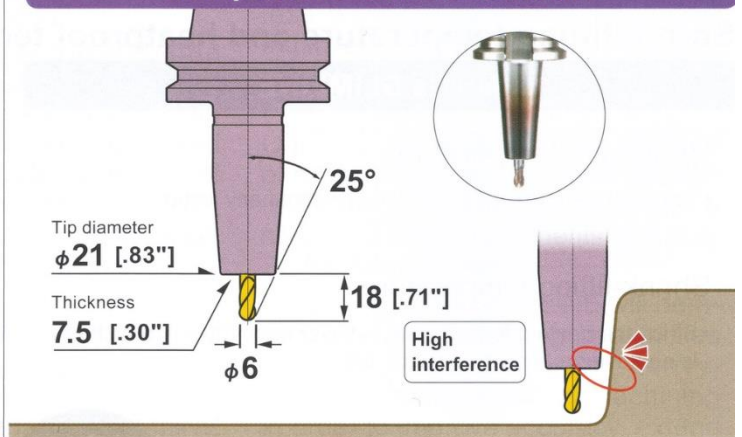

## High rigidity

## Shortest cutter projection

- The cutting tool life is extended and the finishing surface quality is improved tremendously thanks to reduced deflection.

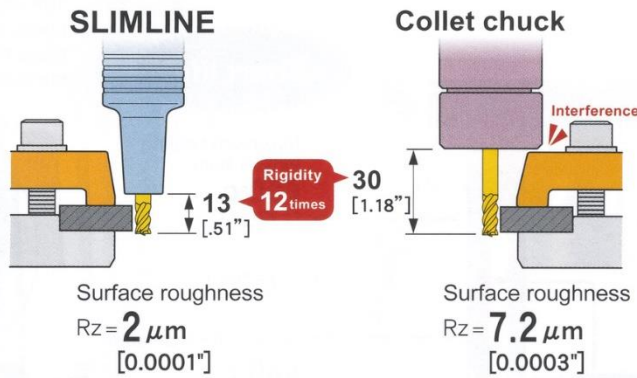

Deflection amount is proportional to **projection length<sup>3</sup>**.

Length becomes **2** times → Deflection amount becomes **8** times

$$S = \frac{6.8 \times F \times L^3}{E \times D^4}$$

S : Deflection amount  
L : Tool projection  
E : Young's modulus  
D : Shaft diameter  
F : Load

## High clamping force

## 3 times greater clamping force (compare with a collet chuck)

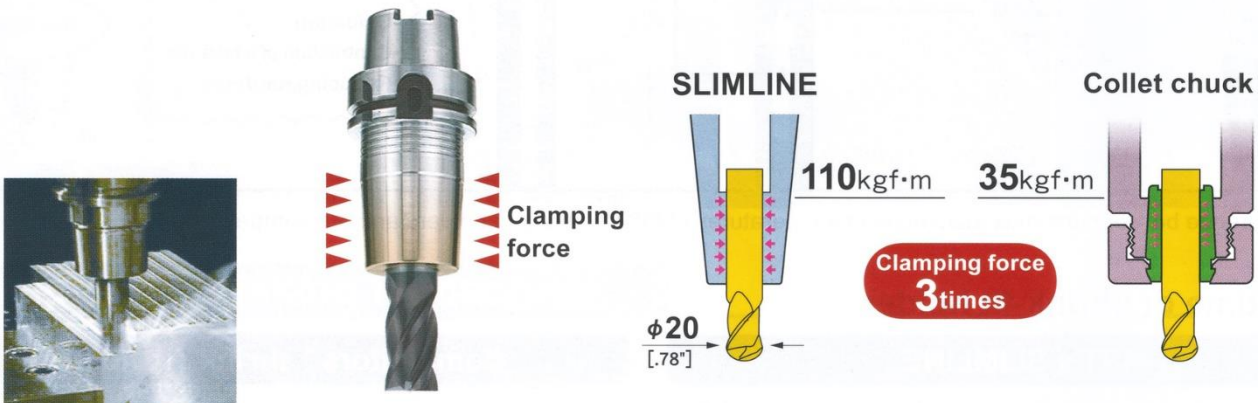

## High run-out accuracy

## Stable high run-out accuracy can be achieved at all times.

- There are no tightening parts (such as nuts and collets) to hold cutters. The simple design maintains high-accuracy chucking.

MONO 3°  
MONO CURVE

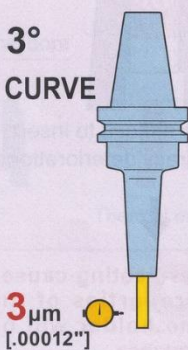

2 PIECE type

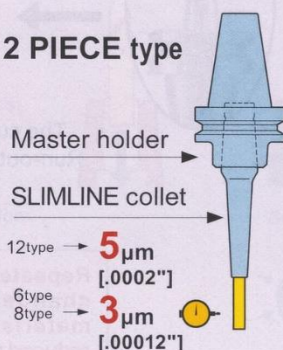

UNO

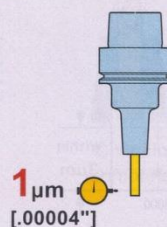

BLACK UNO

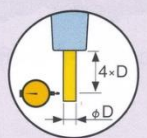
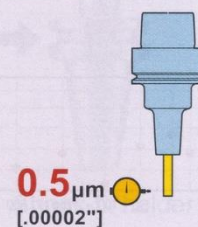



# A broad line-up

MST's shrink-fit holder, SLIMLINE has an amazing line-up for all kinds of applications!  
 You can select the optimal holder from a lineup of **4000** types.



## MONO SERIES

→ P.16

### MONO 3° NEW φ32

Ideal for deep and straight wall milling applications.

**3000** variations

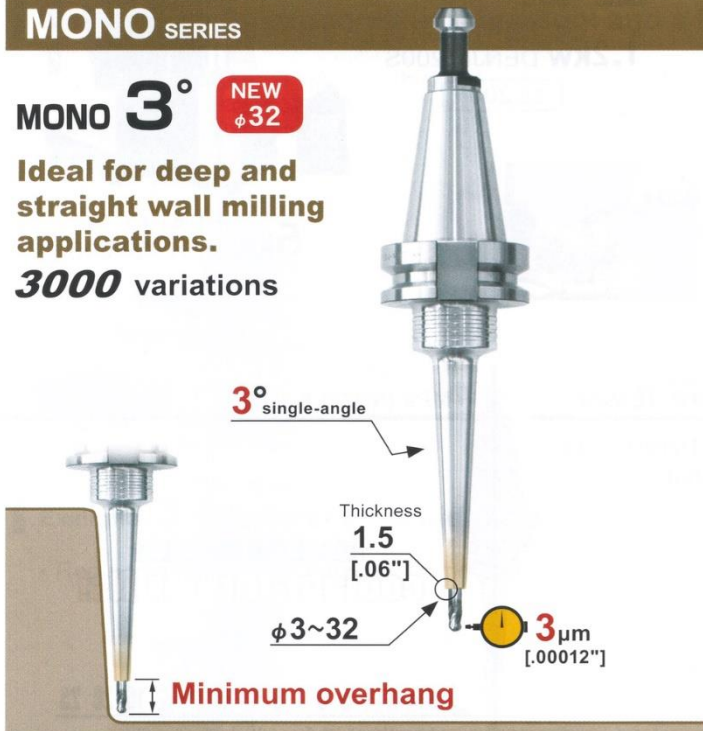

### MONO CURVE PAT.

Ideal for 5-axis applications.

**500** variations

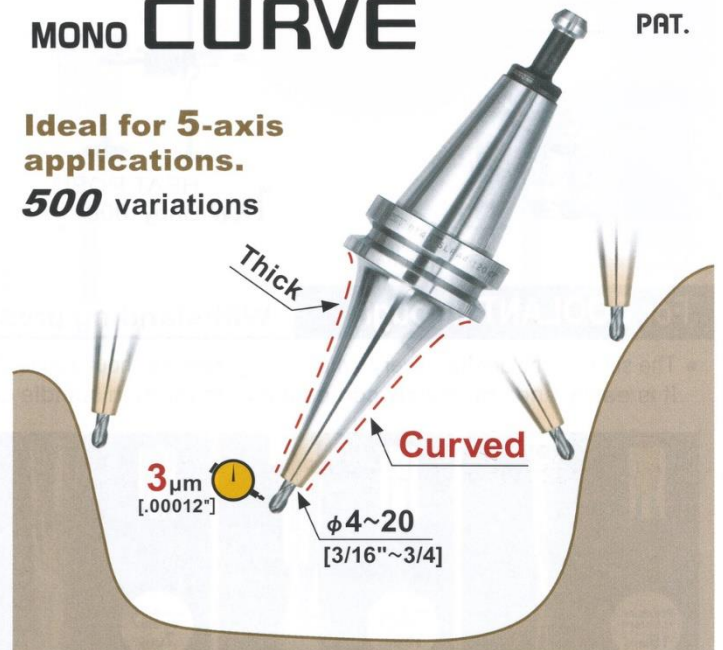

### 2 PIECE type

→ P.213

Highly versatile  
**250** variations

Modular type

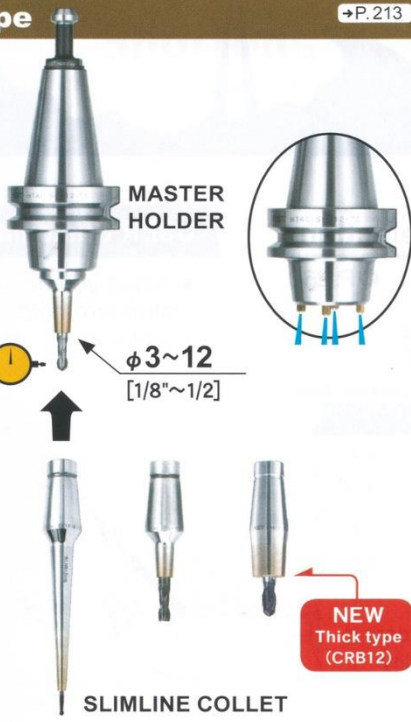

### UNO

→ P.221

Superior accuracy

NEW

BLACK UNO

UNO

PAT.

0.5 μm  
 [0.00002\"/>

1 μm  
 [0.00004\"/>

### HYPER VERSION

→ P.223

Heavy-duty endmill holder  
 with high clamping force

Shortest  
 L dimension

φ12~25

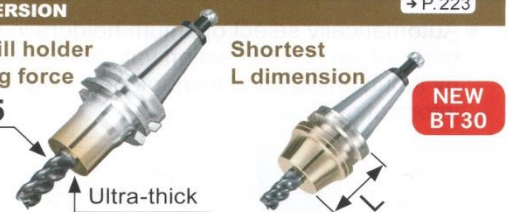

NEW  
BT30

### Z

→ P.227

Anti-pulling out and  
 anti-slippage mechanism

PAT.

φ8~25  
 [5/16\"/>



Cutters never fall out!



# TOOLING SYSTEM

General Catalog

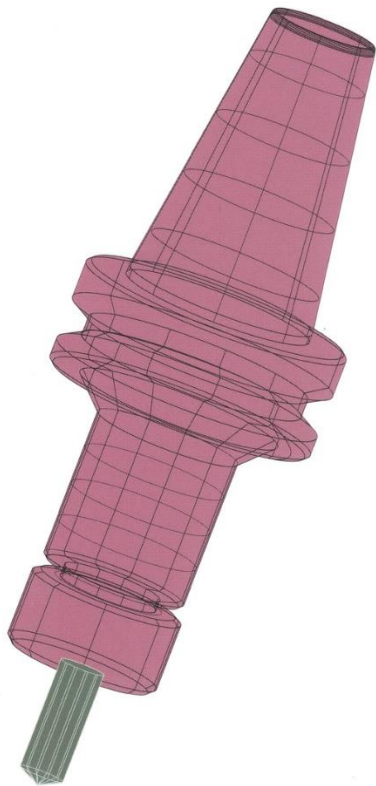

**MST** corporation

Vol. 4   
1901



# A new challenge

By making the most of our accumulated knowledge and experience, we are developing new processing technologies and providing new service.

## ■ Graphite Machining

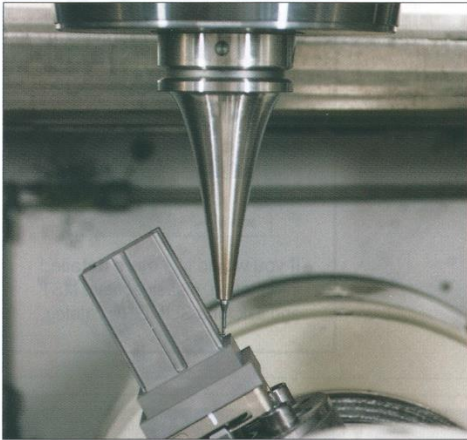

Thailand factory

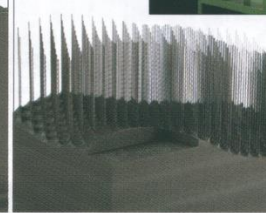

We make graphite electrodes to your specifications. State-of-the-art facilities and production systems offer our customers quick delivery and large-volume order fulfillment.

## ■ Micromachining

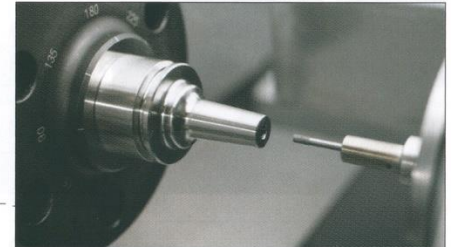
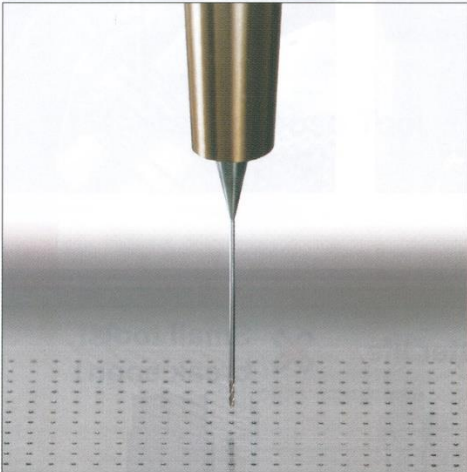

Slimline UNO finishing process

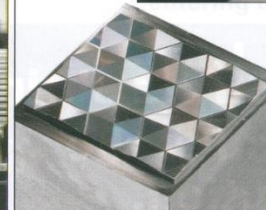
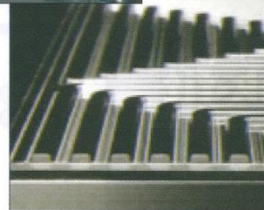

We meet our customers' needs using micron-precision process technology which have been cultivated throughout history.



## RELIABLE TOOLING

MST's tooling is subject to its own MST's 4 accuracy standards: taper contact, roundness, surface roughness and heat treatment. These are more precise than JIS or MAS standards. We provide trustworthy products under strict quality control.

### ● MST's 4 accuracy standards.

1 Taper contact	%	90
2 Roundness	μm	0.8
3 Surface roughness (Rmax)	μm	0.6
4 Heat treatment	Material	SCM415
	Carburized depth	mm 0.8 ~ 1.0
	Hardness	HRC 55° ± 2°

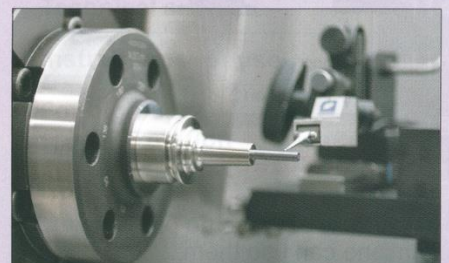
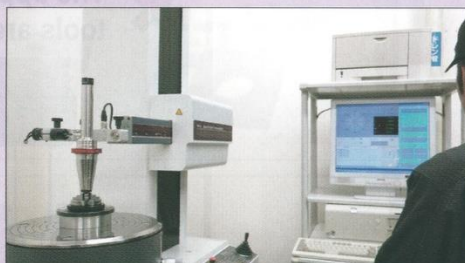
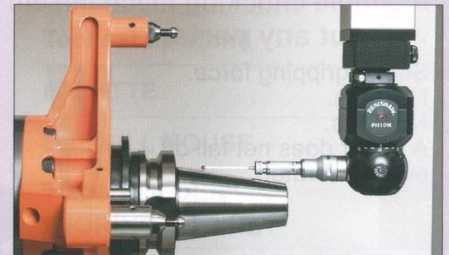



# Master Index

## ANGLE HEAD

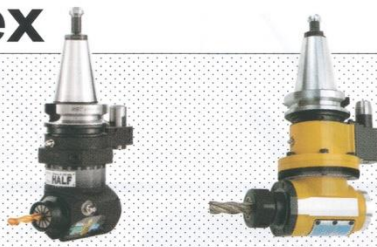

HALF  
STANDARD type

DETa-1 Collet Holder  
COLLET HOLDER  
Hi-ART MILLING CHUCK

## M/C Tool



SUMMIT  
FMH RIGID type  
RED SCREW arbor  
Cutter arbor with spindle-through coolant

MICRO HEAD  
Retention knob

## HSK - T Tooling Systems for Turning Mill



Set screw holders for Round shank  
Insert holders for Square-shank

Universal Facing Boring Head

## General Purpose Tool



SMART GRIP

GOO checker  
Centering bar

## JIG



6S DESK

CLEAN BOX  
TEST BAR CHECKMATE  
TOOL CAP

## Measuring Equipment



Tool set up stand

PALETTE  
ENDMILL HOUSE  
TOOL HOLDER  
STORING CABINET

## Maintenance Tool

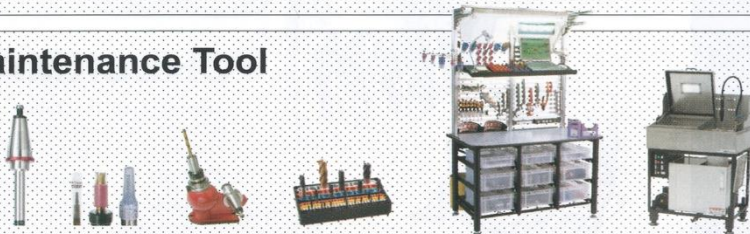

MIDDLE VISE

Wire Cut Unit

## Wire EDM fixture

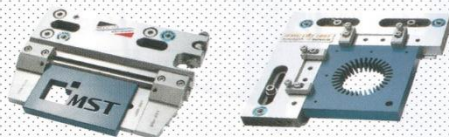

PARTS  
ANGLE HEAD HALF  
PARTS LIST

Technical support  
Instructions for use

For high-speed spindle rotation

## Technical Information

HSK SHANK

Technical data

OVERSEAS NETWORK



For **High-accuracy**, and **High-efficiency** machining

# 5 Points



End-mill



Small size drill

## 1 The shortest

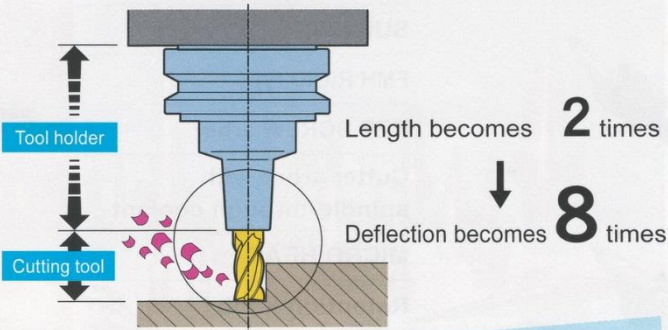

Use shrink-fit holders

with a slim-tip!

As short as possible

Deflection amount is proportional to projection length<sup>3</sup>.

## 2 Selection

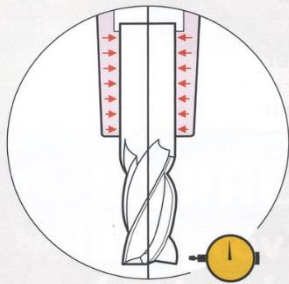

Stronger than collet holders

Clamping force **3** times

Run-out accuracy within **3** microns

Use shrink-fit holders

with strong clamping force and high accuracy!

Choose a tool holder that can clamp a cutting tool securely and with high accuracy.

## 3 Quality

Machining quality and speed



Replace!

Do not use worn cutting tools.

## 4 Cleanliness

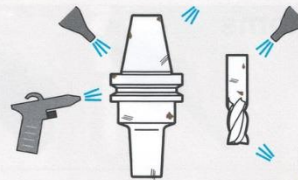

Cutting chips and oil are **your main enemies.**

Use a tool holder washing machine,

**CLEAN BOX!**

Clean your tool holders and cutting tools.

## 5 Accuracy

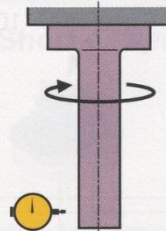

Check

the spindle condition

Use a test bar for dedicated machine spindle maintenance,

**CHECKMATE!**

Machine spindle run-out accuracy should be within 10 microns (.0004").

The shrink fit holder with the slim design, superior gripping force and run-out accuracy.

SHRINK-FIT HOLDER  
**SLIMLINE**



If you would like more detailed information, please contact MST and ask for a SLIMLINE catalog.

Thickness  
**1.5mm (.06")**

**3 μm (.0001")**

Tool holder washing machine

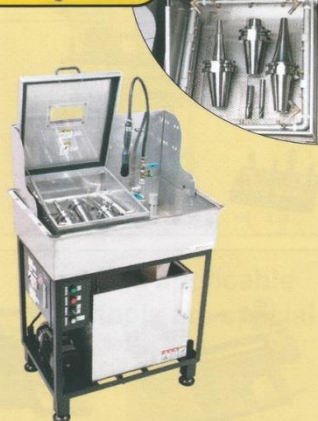

**CLEAN BOX**

Washes tool holders, collets, nuts and cutting tools thoroughly to maintain their high accuracy

→ P.88

TEST BAR

**CHECKMATE**

Ideal for easy machine spindle run-out accuracy checks.

→ P.90

